

V145K Model

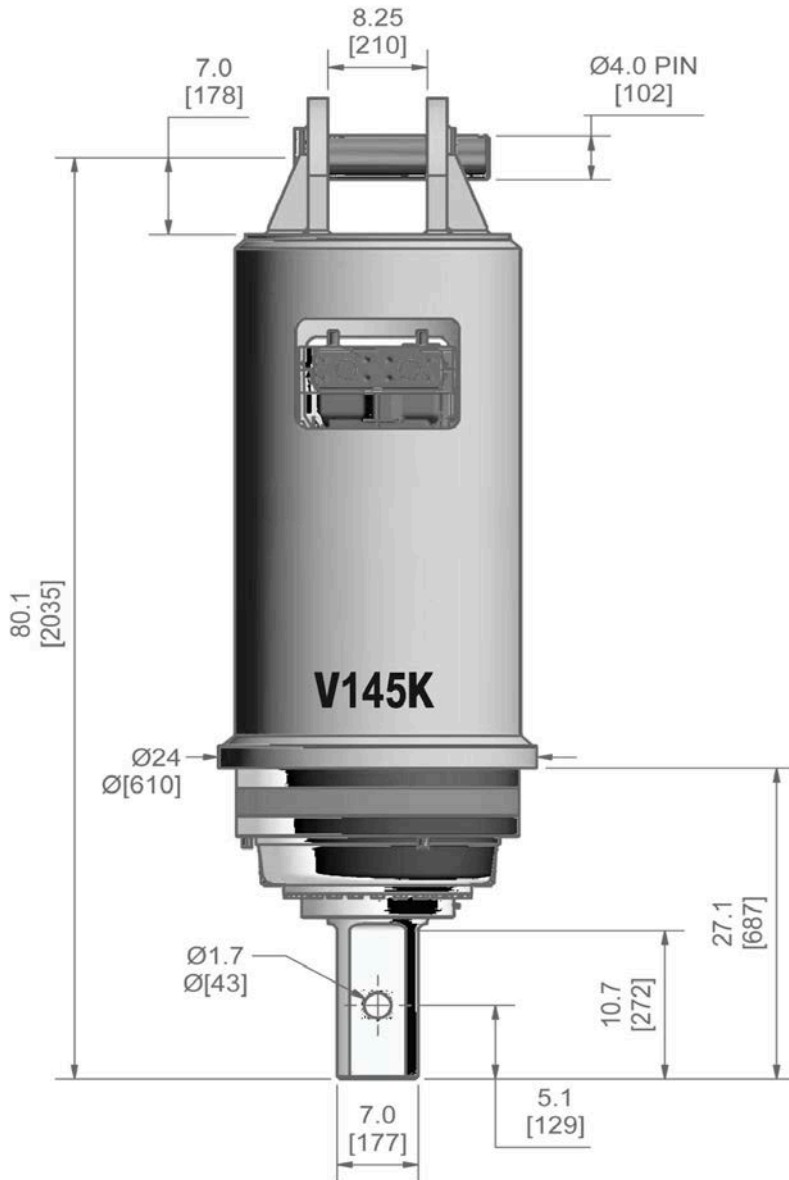

Part Number	V145K
Motor Mount	SAE E 4 Hole
Min. Hydraulic Flow	10 GPM (38 LPM)
Max. Hydraulic Flow	100 GPM (379 LPM)
Max. Continuous Pressure	5000 PSI (345 BAR)
Output Shaft	177mm Square
Weight	Approx. 1700 kg

OUTPUT SPEED		
FLOW GPM (LPM)	RPM Range	-
10 (38)	2-3	-
15 (57)	2-4	-
20 (76)	3-5	-
25 (95)	4-7	-
30 (114)	4-8	-
35 (132)	5-9	-
40 (151)	5-10	-
45 (170)	6-12	-
50 (189)	7-13	-
55 (208)	7-14	-
60 (227)	9-16	-
65 (246)	9-17	-
70 (265)	9-18	-
75 (284)	10-20	-
80 (303)	11-21	-
90 (341)	12-24	-
100 (379)	13-26	-

OUTPUT TORQUE		
PRESSURE PSI (BAR)	TORQUE LOW FT/LBS (Nm)	TORQUE HIGH FT/LBS (Nm)
1000 (69)	10770 (146604)	21539 (29207)
1200 (83)	12924 (17524)	25847 (35048)
1400 (86)	15078 (20445)	30155 (40890)
1600 (110)	17231 (23366)	34462 (46731)
1800 (124)	19385 (26286)	38770 (52572)
2000 (138)	21539 (29207)	43078 (58414)
2200 (152)	23693 (32128)	47386 (64255)
2400 (166)	25847 (35048)	51694 (70066)
2600 (179)	28001 (37969)	56001 (75938)
2800 (193)	30155 (40890)	60309 (81779)
3000 (207)	32309 (43811)	64617 (87621)
3200 (220)	34463 (46731)	68925 (93462)
3400 (234)	36617 (49652)	73233 (99303)
3600 (248)	38770 (52573)	77540 (105145)
3800 (262)		81848 (110986)
4000 (275)		86156 (116828)
4200 (289)		90464 (122669)
4440 (303)		94772 (128510)
4600 (317)		99079 (134352)
4800 (330)		103387 (140193)
5000 (344)		107695 (146034)

Note: 1 Ftlb = 1.356 Nm